



spektra **direkt2**

Crossover Machine

USER MANUAL



2018

MACHINE OVERVIEW

PACKAGE CONTENTS

- Direkt 2 MachineBody
- Spektra HexDrive MotorBolt
- 1/16" Allen Key
- 2.8mm Stroke Cap
- 4.0mm Stroke Cap
- Stroke Changing Tool
- 2 Tensioner O-rings
- 2 Spare 1-72 1/8" Socket Head Stroke Securing Screws

MACHINE FEATURES

- Compatible with standard style needles and tubes or cartridges without the need for removing or changing parts.
- Patent pending needle clip and needle stabilizer eliminates the need for grommets or rubber bands.
- Patented HexDrive engagement mechanism eliminates axial load on the motor shaft extending motor life.
- Interchangeable stroke caps in 2.8mm, 3.4mm and 4.0mm sizes.
- Dually compatible patent pending collet vise system supports standard back stem (5/16" - 8mm dia.) and screw on adjustable grips.
- Virtually vibration free.
- No maintenance required.
- Lightweight at only 2.85oz / 80g.
- 4.5 Watt Swiss Maxon motor.
- Made in the USA.

MACHINE PARTS

1. Vise Chuck
2. Vise Collet
3. Vise O-ring
4. Vise Receiver
5. Machine Body
6. Tensioner O-ring
7. Tensioner Knob
8. Clip-on Armature
9. Stroke Cap
10. Hex Drive
11. MotorBolt O-ring
12. MotorBolt
13. RCA

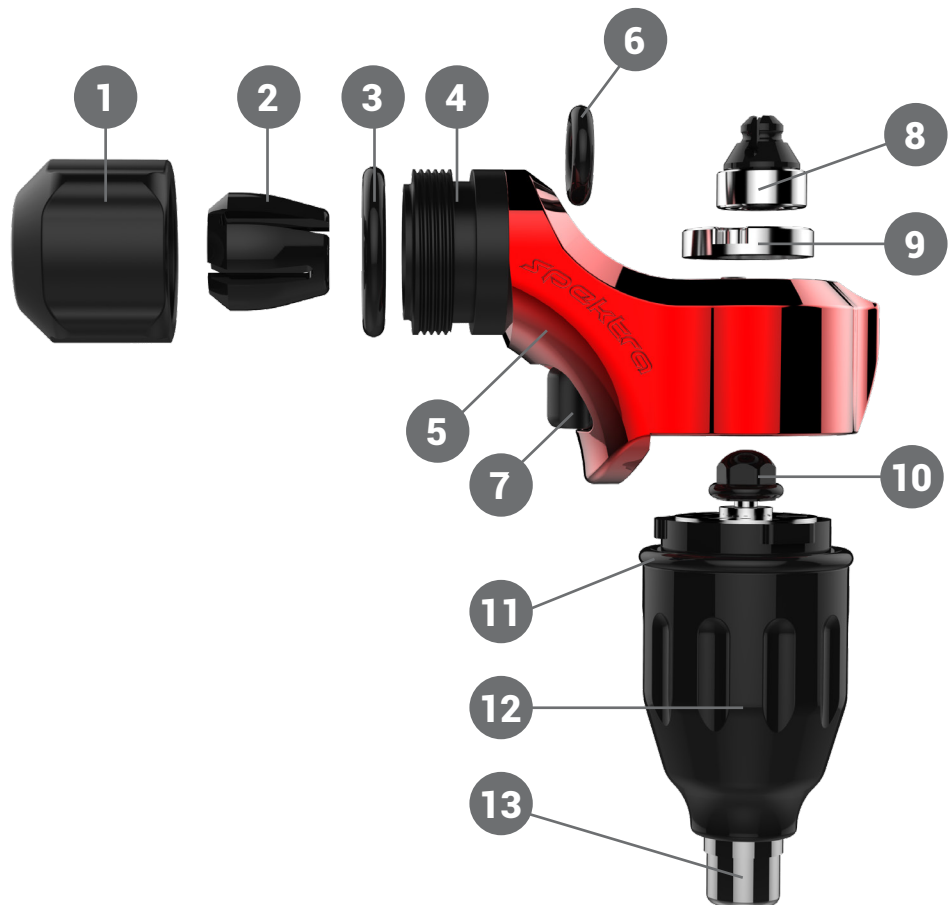

USING THE DUALY COMPATIBLE VISE AND NEEDLE CLIP

The Spektra Direkt 2's patent pending collet vise system is compatible with both standard backstem style tubes (5/16" - 8mm dia.) and screw-on-style adjustable cartridge grips (with a M16x1mm female threading).

Fully assembled, the machine is set up to accept a standard backstem style tube. To use the machine with cartridges, first insert the needle by unscrewing the outer vise chuck (1) enough to loosen the knob but not fully remove it, and gently guide the looped end of the cartridge drive bar through the vise and under the loosened tensioner O-ring. Do not bend the drive bar prior to inserting it into the machine.

Next, turn the eyelet of the drive bar 90 degrees next to the Clip-on Armature (8) and gently press the needle bar loop onto the Armature clip to secure it in place. Ensure that the drive bar is centered in the vise. When using cartridges, it is not necessary to utilize the adjustable tensioner feature, however, slight tension may be applied in order to eliminate any side to side play of the needle.

Gently glide the backstem of the tube over the drive bar or needle, and insert it into the opening through the vise chuck and collet. Tighten the chuck to lock the grip into position.

In order to use a screw-on-style grip, fully unscrew the vise chuck (1) and remove the chuck and the exposed collet (2) from the machine. Attach the drive bar to the needle clip and carefully insert the grip over the exposed drive bar. Attach the grip to the exposed threads of the vise receiver (4).

Store the removed chuck and collet in a safe place. To transition the machine to accept standard backstems, simply reinsert the collet with the narrow end pointed into the vise opening and secure the chuck onto the male threading.

USING THE ADJUSTABLE TENSIONER WITH STANDARD NEEDLES

The Direkt 2 introduces the first adjustable tensioner available on a direct drive machine. In order to use the tensioner with standard style needles and tubes, begin setup by introducing a slight bend to the needle bar and ensure that the tensioner is open with no applied tension prior to inserting the needle. You may also bend the needle down slightly at the needle stack especially if working with open mag tubes as these tend to require additional needle tension.

Next, set up the machine similarly to the Cartridge Drive Bar using the steps listed above to guide the eyelet of the needle bar horizontally through the tensioner O-ring. Once the eyelet is guided through the tensioner, turn the eyelet 90 degrees so that it is vertical next to the Armature Clip and gently snap it into place. The Armature Clip has been designed to accept eyelets of all standard sizes, so all needle brands will be compatible.

Once the needle bar is secured in place, gently apply tension to the bar by twisting the tensioner adjustment knob counterclockwise until the needle bar is centered in the backstem of the tube. You will want to use the smallest amount of tension possible that will keep the bar centered in the O-ring and the backstem of the tube.

Be careful not to overtighten the tensioner past the mid-point of the needle in the tube as this could cause overworking of the motor, grinding of the needle on the tube or other adverse performance of the machine.

Adjust the tension of the needle on the fly to suit your tattooing preferences keeping in mind that slight tension adjustments may need to be made as the machine runs at higher or lower voltages.

MACHINE OVERVIEW

REMOVING DRIVE BARS OR NEEDLES

In order to remove the drive bar or needle from the Clip-on Armature, gently pull the bar up from the front of the armature between the armature pin and machine vise. Do not attempt to pry off the bar from the rear or the machine or by using additional tools as this could cause damage to the Armature Clip.

Next, loosen the adjustable tensioner by turning the knob clockwise, and gently remove the needle bar from the front of the machine by pulling it under the tensioner O-ring.

REPLACING THE TENSIONER O-RING

In order to change the tensioner O-ring, begin by turning the Tensioner Knob clockwise until the Tensioner Base is freed from the Tensioner Knob.

Carefully remove the Tensioner Base ensuring the spring contained within the base's threads is kept in place. Next, gently remove the O-ring from the O-ring clip of the tensioner base, and insert a new O-ring into the O-ring clip. Once the O-ring is in place, insert the O-ring and Tensioner Base into the machine with the O-ring pointing towards the vise of the machine until the threading of the Tensioner Base is coupled with the Tensioner Knob. It is important that the O-ring is inserted facing the proper direction as an O-ring aligned closer toward the armature of the machine will not enable proper machine function.

Once inserted, tighten the Tensioner Knob counter clockwise in order to secure the new tensioner O-ring and base into place.



CHANGING THE STROKE

The stroke of the Direkt 2 is interchangeable between 2.8mm, 3.4mm and 4mm sizes using the included Stroke Caps.

In order to change the stroke of the machine, release the MotorBolt unit from the Machine Body and insert the Stroke Changing tool into the motor's place; this will prevent the cam from turning as you swap the stroke caps.

Next, use the Allen key included to gently remove the 2 socket head screws securing the stroke cap and set screws aside.

Gently remove the installed Stroke Cap and replace it with your selected size. Insert the 2 screws into the Stroke Cap's holes, but do not tighten. In order to ensure you do not misalign or over-torque the screws, gently screw in the socket head screws 1 to 2 turns alternating between the 2 screws until the Stroke Cap is fully secured onto the machine. Remove the Stroke Changing Tool, insert the motor and use the machine at your desired stroke length.

Choosing a Stroke Length:

Ultimately, artist preference dictates the best stroke length for a particular style or technique. Below are some basic guidelines:

3.6mm - This stroke is mounted standard on each machine as it tends to be the most versatile and best for all around tattooing styles. Suitable for lining, shading, color packing and all styles of tattooing.

2.8mm - This shorter stroke length is generally recommended for soft black and grey.

4.0mm - This longer stroke length is recommended for use as a longer stroke liner and for filling in large areas of saturated color.



ADDITIONAL INFORMATION

MAINTENANCE AND TIPS

The Spektra Direkt 2 requires no standard maintenance or lubrication. The following tips, however, will help ensure the longevity and optimal performance of the machine:

When choosing your needle and tube sizes with standard set-ups, it is important to ensure that these sizes are compatible with one another. Due to the circular motion of the machine, using a tube size that is too large for your chosen needle size (for example, a 9mag in an 11mag tube) could result in additional noise and subpar performance of your equipment.

It is recommended to add standard tattooing ointment to the O-ring and/or needle bar prior to use in order to ensure smooth performance and longevity of the tensioner O-ring. Two of the additional tensioner O-rings are included with each new machine. Additional O-rings are available for purchase at www.fkirons.com.

LIFETIME WARRANTY

FK Irons warrants that the product will perform efficiently when used by a Professional Tattoo Artist. All Machine Body components not subjected to normal wear and tear will be covered under warranty for the life of the machine. The enclosed Maxon Motor will be covered under warranty for 1 year from the date of purchase. Should this product be defective, FK Irons will repair or replace the product for a current available model of equal value.

This warranty will become void if the Maxon Motor is removed from the MotorBolt casing, if the machine has undergone unnecessary rough handling, repeated dropping, overexposure to moisture and/ or lubricant or neglect. For warranty claims, replacement parts, or general service inquiries, please read the Frequently Asked Questions of www.fkirons.com or contact a representative via email at service@fkirons.com.

For service inquiries, warranty claims or replacement parts, please contact service@fkirons.com or via phone at 1-855-FKIRONS. For additional tips and tutorials, please visit [Youtube.com/fkirons](https://www.youtube.com/fkirons).